

## Standard Captive U Type Nuts

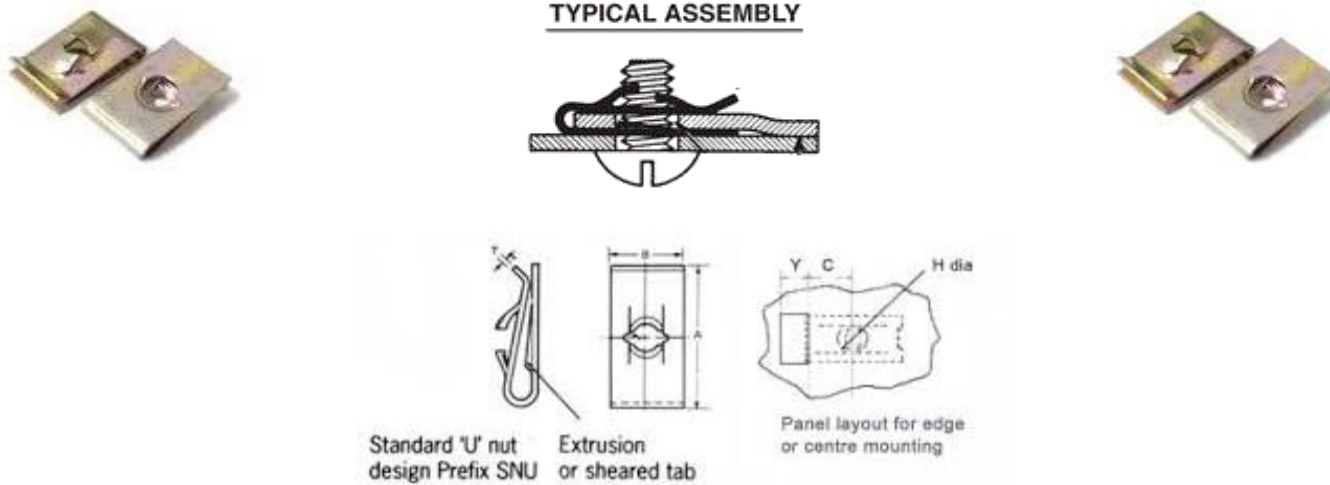

**Standard Captive U Type Nuts Are Available To Suit A Range Of  
No:4 - No:6 - No:8 - No:10 - No:12 - No:14 Self Tapping Screws  
And  
M4 - M5 - M6 - 6BA - 4BA - 2BA Machine Screws  
And Are Manufactured From Carbon Steel Hardened And Tempered  
And Are Available: Self Colour - Zinc Plated - Zinc And Yellow Passivated**

**Due To The Many Variations Of U Type Nuts When Enquiring It Would Be Appreciated That The Above Dimensions Are Provided Along With The Panel Thickness Range And Size Of Screw To Be Used**